

SUBMERSIBLE PUMPS

KS SERIES

SUBMERSIBLE PUMPS

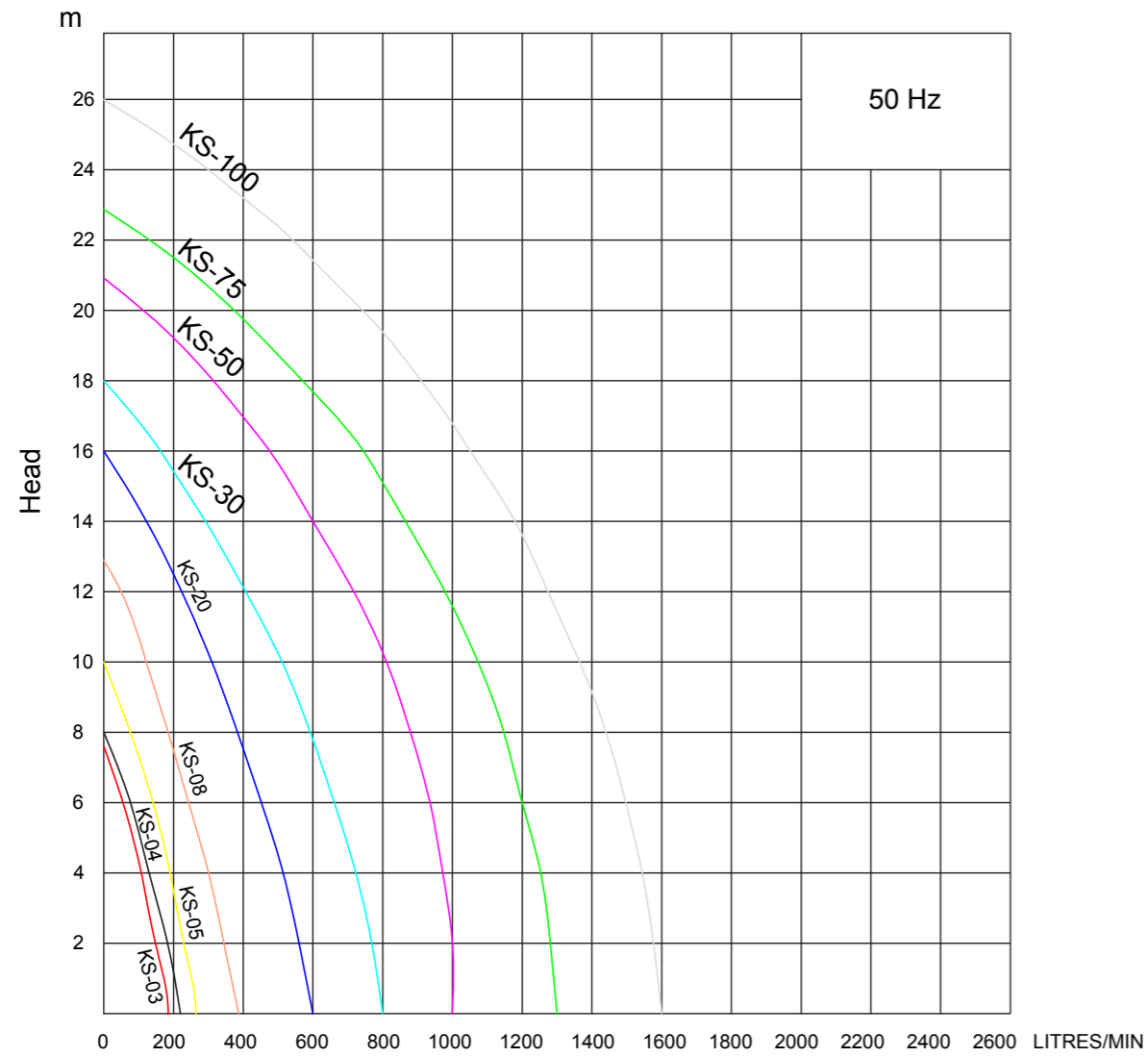

FEATURES	
IP 68 Protection & F Class insulation	
Low temperature operation for long service life	
Built in thermal overload protector	
Double mechanical seal available for 1HP and above	
High efficiency hydraulic suction for energy saving	

APPLICATIONS	
Drainage or cellar	
Groundwater effluent	
Civil engineering & construction	
Agriculture & irrigation	
Tunnel & caisson drainage	



DIMENSIONS

KS SERIES

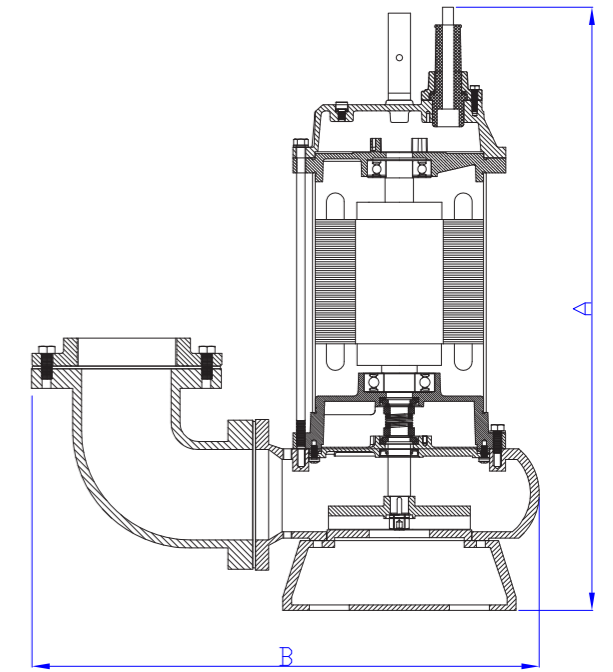

MODEL NO.	A	B	C
KS-03	188mm	230mm	140mm
KS-04	208mm	230mm	140mm
KS-05	360mm	230mm	140mm
KS-08	433mm	277mm	156mm
KS-10	461mm	277mm	193mm
KS-20	494mm	291mm	193mm
KS-30	516mm	467.4mm	458.3mm
KS-50	546mm	467.4mm	458.3mm
KS-75	616mm	551mm	221mm
KS-100	680mm	517.7mm	331mm

MODEL NO.	OUTPUT		DISCHARGE		RATED		MAXIMUM		WEIGHT kg	DIMENSION L X W X H (mm)
	HP	kW	mm	INCH	HEAD m	CAPACITY LPM	HEAD m	CAPACITY LPM		
KS-03	1/3	0.25	40	1 1/2"	3	130	8	180	9	188 X 141 X 305
KS-04	1/2	0.4	50	2"	5	150	8	220	11	208 X 140 X 359
KS-05	1/2	0.4	50	2"	5	160	10	260	14	230 X 156 X 375
KS-10	1	0.75	50 (80)	2"(3")	6	240	13	380	21	290 X 180 X 425
KS-20	2	1.5	80	3"	10	300	16	600	31	278 X 182 X 475
KS-30	3	2.2	80	3"	10	500	18	800	42	390 X 250 X 450
KS-50	5	3.7	100	4"	10	800	21	1100	48	450 X 240 X 530
KS-75	7.5	5.6	100	4"	15	800	23	1300	60	550 X 310 X 590
KS-100	10	7.5	150	6"	18	900	26	1600	70	550 X 310 X 610