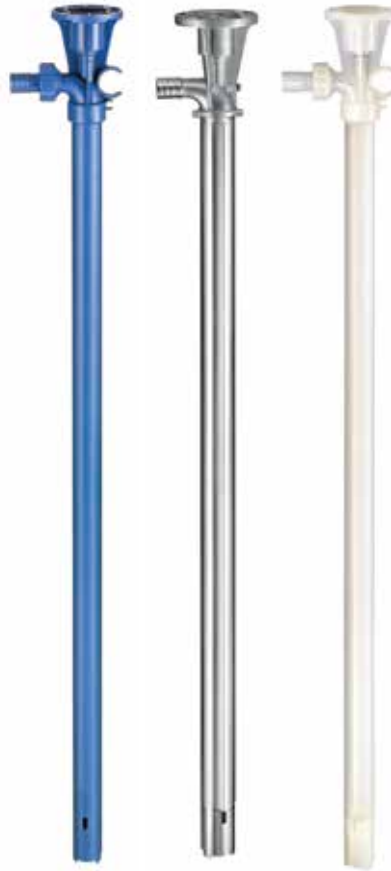




FINISH THOMPSON INC.

EF SERIES PUMPS

EFP, EFS, & EFV OPERATION & PARTS MANUAL





FINISH THOMPSON INC.

921 Greengarden Road • Erie, PA 16501-1591 U.S.A.
Ph 814-455-4478 • Fax 814-455-8518
Email fti@finishthompson.com • www.finishthompson.com

EU Declaration of Conformity



Finish Thompson Inc. hereby declares that the following machine(s) fully comply with the applicable health and safety requirements as specified by the EC Directives listed. The product may not be taken into service until it has been established that the drive motor for the Drum and Container Pump complies with the provisions of all relevant EC Directives. The complete product complies with the provisions of the EC Directive on machinery safety provided motors manufactured by Finish Thompson Inc. are used. This declaration is valid provided that the devices are fully assembled and no modifications are made to these devices.

Type of Device:

Drum and Container Pump Tubes

Models:

BTS - 40
HVDP LR-27/40/48
PFP-15/27/40/48/60/72
TBP-27/40/48
STTS-40

EPPI/EPSS 15/27/40
HVDP HR-27/40/28
PFS-27/40/48/60/72
TBS-40
TMS-40

EFP/EFV/EFS-16/27/40/48
PFM-27/40/48/60
PFV-27/40/48/60/72
TTC/TTS-27/40/48

EC Directives:

Machinery Safety (2006/42/EC)

Applied Harmonized Standards:

EN ISO 12100 Part 1
EN ISO 12100 Part 2
EN 809

Manufacturer:

Finish Thompson Inc.
921 Greengarden Road
Erie, Pennsylvania 16501-1591 U.S.A

Signed,

President

January 7, 2013

Person(s) Authorized to Compile Technical File: Michael Smith Engineers Limited
Oaks Road, Woking, Surrey
GU21 6PH, UK
Telephone: 01483 771871

Introduction

This manual pertains to the EF Series drum pumps. Finish Thompson Inc. thanks you for choosing our products. We believe the use of our products will be fully satisfactory. When properly installed and operated, your Finish Thompson motor and pump will provide long, trouble-free service; therefore, please read this manual carefully before carrying out any operations on the pump/motor unit. Any use other than that described herein is considered incorrect; and, consequently, Finish Thompson Inc. shall not be held responsible for any damages to people or property. In case of doubt or enquiries, please reply to our Technical Service department directly at the following address:

Finish Thompson, Inc.
921 Greengarden Rd.
Erie, PA 16501 U.S.A.
Tel. 1-814-455-4478; Fax 1-814-455-8518
www.finishthompson.com; fti@finishthompson.com

Index

Introduction/ Pump Specifications	1
Warranty, General Terms & Conditions	2
Safety.....	3
Specifications & Dimensions	4
Disassembly	5-6
Reassembly.....	6-7
Exploded Views – EFP/EFV/EFS Pump Tubes.....	8-9
Pump Tube Spare Parts List.....	10-11

Note: Repair instructions can be downloaded from our web site at www.finishthompson.com or contact Technical Service at 1-800-888-3743.

Warranty, General Terms & Conditions

1. The following terms and conditions apply to the sale of machinery, components and related services and products, of Finish Thompson Inc. (hereinafter “the products”)
2. Finish Thompson Inc. (the manufacturer) warrants only that:
 - a) its products are free of defects in material, design and workmanship at the time of original purchase;
 - b) its products will function in accordance with Finish Thompson Inc. operation manuals; Finish Thompson Inc. does not guarantee that the product will meet the precise needs of the Customer, except for those purposes set out in any invitation to render documents or other documents specifically made available to Finish Thompson Inc. before entering into this agreement;
 - c) high quality materials are used in the construction of the pumps and that machining and assembly are carried out to the highest standards. Except as expressly stated above, Finish Thompson Inc. makes no warranties, express or implied, concerning the products, including all warranties of fitness for a particular purpose.

This warranty shall not be applicable in circumstances other than defects in material, design, and workmanship. In particular warranty shall not cover the following:

- d) Periodic checks, maintenance, repair and replacement of parts due to normal wear and tear;
- e) Damage to the product resulting from:
 - i. Tampering with, abuse or misuse, including but not limited to failure to use the product for its normal purposes as stated at the time of purchase or in accordance with Finish Thompson, Inc. instructions for use and maintenance of the product, or the installation or improper ventilation or use of the product in a manner inconsistent with the technical or safety standard in force;
 - ii. Repairs performed by non-authorized service workshop, or opening of the unit by non-authorized personnel, or use of non genuine Finish Thompson Inc. parts;
 - iii. Accidents, force majeure or any cause beyond the control of Finish Thompson Inc., including but not limited to lightning, water, fire, earthquake, and public disturbances, etc.
3. The warranty shall cover the replacement or repair of any part, which is documented to be faulty due to construction or assembling, with new or repaired parts free of charge delivered by Finish Thompson, Inc. Parts subjected to normal wear and tear shall not be covered by the warranty. Finish Thompson, Inc. shall decide as to whether the defective or faulty part shall be replaced or repaired. Transportation charges are prepaid to Finish Thompson.
4. The warranty of the products shall be valid for a period of **12 months** from the date of delivery, under the condition that notice of the alleged defect to the products or parts thereof be given to Finish Thompson, Inc. within the term of 8 days from the discovery.
5. Repair or replacement under the terms of this warranty shall not give a right to an extension to, or a new commencement of, the period of warranty. Repair or replacement under the terms of this warranty may be fulfilled with functionally equivalent re-conditioned units. Finish Thompson Inc. qualified personnel shall be solely entitled to carry out repair or replacement of faulty parts after careful examination of the motor. Faulty parts or components when replaced by Finish Thompson Inc. will become the property of Finish Thompson Inc. If this warranty does not apply, the purchaser shall bear all cost for labor, material and transportation.
6. Finish Thompson Inc. will not be liable on any claim, whether in contract, tort, or otherwise, for any indirect, special, incidental, or consequential damages, caused to the customer or to third parties, including loss of profits, process down time, transportation costs, costs associated with replacement or substitution products, labor costs, installation or removal costs. In any and all events, manufacturer’s liability shall not exceed the purchase price of the product and/or accessories.
7. **Return Policy.** Should you have any problems with this product, please contact the distributor in your area. The distributor will determine if a return to the factory is necessary and will contact the factory for a Return Authorization Number. Otherwise, contact our Technical Service Hotline (1-800-888-3743) or e-mail techservice@finishthompson.com if you have any questions regarding product operation or repair.

Safety

1. Introduction

This manual contains all the information needed for the correct installation, use and maintenance of your new Finish Thompson pump. It should be read and understood by all the personnel involved in installation, operating and servicing of the pump before it is started.

2. Operator Qualification and Training

The personnel in charge of the installation, the operation, and the maintenance of the pump must be qualified and able to perform the operations described in this manual. Finish Thompson, Inc. shall not be held responsible for the training level of personnel and for the fact that they are not fully aware of the contents of this manual.

3. Safety Instructions

⚠️ FOR YOUR OWN SAFETY

BEFORE using or servicing your pump, please make sure to wear the proper clothing, eye protection and follow standard safety procedures when handling corrosive or personally harmful materials.

⚠️ GENERAL DANGER

NEVER use a plastic pump or an open, splash-proof, TEFC or non-ATEX motor when pumping or mixing flammable or combustible material.

ALWAYS use a Model EFS 316SS pump tube with Model S4 air motor and static protection kit with grounded discharge hose, P/N 107429, when pumping or mixing flammable or combustible material. Follow Assembly, Installation & Operating Instructions from manual, P/N J102721, included with the static protection kit or it can be accessed online at www.finishthompson.com/downloads.

ALWAYS use and store the pump and motor in an upright position.

⚠️ DANGER: POWER SUPPLY

Refer to instructions in the appropriate motor Operation & Installation Manual.

4. Noise Level

Refer to specifications in the appropriate motor Operation & Installation Manual.

5. Modifications and Spare Parts

Any changes concerning the service of the pump as originally purchased can be executed only after written approval from Finish Thompson Inc. It is recommended to use only genuine Finish Thompson Inc. spare parts and approved accessories. The use of non-original spare parts or non-approved accessories will void warranty and removes any responsibility on the manufacturer's behalf for any damage caused to people or things.

6. Cleaning

It is highly recommended to flush pumps with clean water or some other neutralizing fluid compatible with pump materials when done pumping or when switching chemicals.

Hose & Cord Storage

EFP & EFV model pumps have a built-in hose & cord clip. You can use these clips to store your hose and keep the plug off the floor, free of damage and corrosion. When selecting a discharge hose, you should use a 3/4" ID reinforced chemically compatible hose secured with a stainless steel hose clamp. See figures A and B below.

Figure A

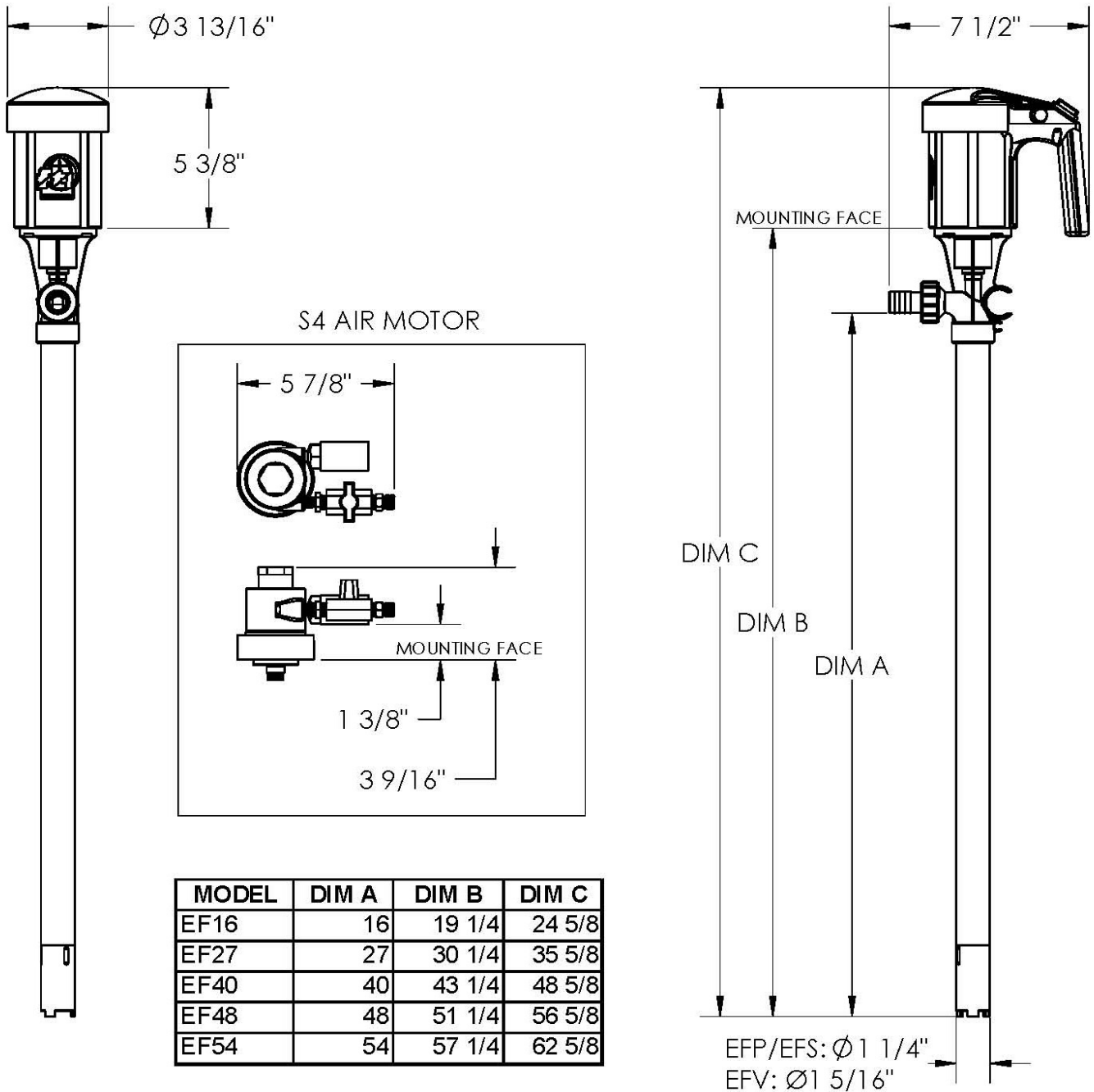


Figure B



PUMP SPECIFICATIONS			
	MODEL EFP	MODEL EFV	MODEL EFS
Outer Tube Diameter	1-1/4" (3.22 cm)	1-5/16" (3.3 cm)	1-1/4" (3.2 cm)
Discharge Spout	3/4" Barb	3/4" Barb	3/4" Barb
Discharge Thread	1" NPT	1" NPT	Optional
Max. Specific Gravity	1.6	1.6	1.6
Max. Viscosity	300 cP	300 cP	300 cP
Min./ Max. Fluid Temperature	0° F Min. to 150° F Max.	0° F Min. to 160° F* Max.	0° F Min. to 212° F Max.
	(-18° C Min. to 66° C Max.)	(-18° C Min. to 71° C* Max.)	(-18° C Min. to 100° C Max.)
Wetted Materials	Polypropylene, FKM, PTFE, ETFE, 316 SS	Pure Polypropylene, PVDF, FKM, PTFE, ETFE, Alloy 625	316 SS, FKM, PTFE, ETFE

*EFV-54 Maximum Temperature = 150° F (66° C)



DISASSEMBLY & REASSEMBLY INSTRUCTIONS

Disassembly

1. **Prior to disassembly** - remove the motor and discharge tubing.
2. **Diffuser Removal - For EFP & EFV Models** – When looking at the bottom of the pump, loosen the diffuser (item 17) by turning it clockwise (left-hand thread) 2-3 turns or until it touches the impeller (item 18). *See figure 1.*



Figure 1

3. **Impeller Removal** - Using a flat-head screwdriver, unthread the impeller (item 18) by turning it counter clockwise (right-hand thread). Hold the coupling insert and coupling (items 1 & 2) in one hand, and unthread with the other. Note: If the shaft unthreads from the coupling, use a pliers to hold the top of the shaft. Care should be taken to not damage the shaft threads. For longer 40” and 48” pump lengths, two people may be required to hold the shaft and unthread the impeller. *See figure 2.*



Figure 2

4. Unthread the impeller roughly 10 turns or until loose.
5. Now finish unthreading the diffuser. If the impeller is loose, it will come off with the diffuser.
6. To remove the impeller from the diffuser, shake it until it engages the impeller guard inside the diffuser, and turn it counter clockwise with a flat head screwdriver or your fingers.
7. **Diffuser Removal - For EFS Models** - Unthread the diffuser cover (item 19). Turn it clockwise (left-hand thread). Unthread the impeller (item 18) turning it counter clockwise (right hand thread) using a flat-head screwdriver or hand while holding the coupling insert and coupling (items 1 & 2) with the other hand. Note: If the shaft unthreads from the coupling, use a pliers to hold the top of the shaft. Care should be taken to not damage the shaft threads. For longer 40” and 48” pump lengths, two people may be required to hold the shaft and unthread the impeller. Unthread the diffuser (item 17) turning it clockwise (left-hand thread).
8. **Shaft Removal** - for all models - To remove the shaft (item 4), tap the bottom of the shaft on a piece of wood or plastic and push the shaft up and out of the head (item 6). Grab the half coupling or bearing and pull the shaft assembly straight out of the head. Note: Take care to not bend the shaft. **Important** - The shaft should only be removed if the bearing is frozen and needs to be replaced.
9. **Outer Tube Removal** - For EFP & EFV Models - Remove the outer tube (item 16). Hold the head (item 6) in one hand and with the other hand, turn the outer tube clockwise (left-hand thread). When completely unthreaded, pull the outer tube away from the head exposing the inner tube and center support (items 13 & 14).
10. **Inner Tube & Center Support Removal** - To remove the inner tube and center support, turn the inner tube to unseat the o-rings (item 12) and then pull the inner tube away from the head.
11. **Shaft Sleeve Removal** - The shaft sleeve (item 15) will drop out of the inner tube by holding it in a vertical position and turning.
12. **Center Support Removal** - 40” and 48” lengths only - If the center support (item 14) needs to be replaced, it can be removed by spreading open the fingers and disengaging it from the inner tube. *See figure 3.*

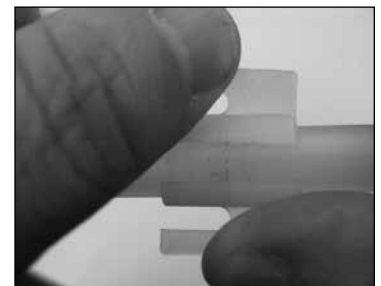


Figure 3

13. **Inner Tube & Shaft Sleeve Removal** - The outer tube and head for EFS models are welded together. To remove the inner tube and shaft sleeve (items 13 & 15 indicated on the Exploded View on pg. 8-9), hold the outer tube and head assembly in a vertical position, and the shaft sleeve will fall out. To remove the inner tube, “pretend” to hit the bottom of the pump on the floor but stop before it actually hits. This motion will allow the weight of the inner tube to release the o-rings, and it will drop out of the bottom of the pump. It is recommended to do this over a soft surface to prevent damaging the inner tube as it drops out of the pump.

14. **Seal Removal** - To remove the seal (item 5) from the head (item 6 or item 16 for EFS), use a hook tool, available at most hardware stores, to pull the seal out from the top of the head. Take care not to damage the seal seat area. *See figure 4.* Note: The seal should be replaced if worn or the bearing is failing or frozen.

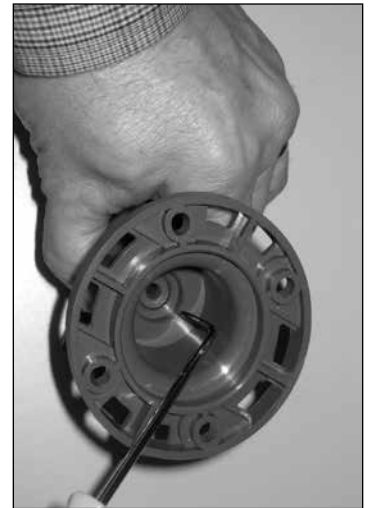


Figure 4

Reassembly

1. **Seal Installation for EFP & EFV models** - Take the head (item 6), and for EFS models take the outer tube with head (item 16), and install a new seal (item 5). Insert the open part of the seal into the lower bore of the head. *See figure 5.* Use a 3/8” (9.5 mm) dowel to press and seat the seal into place. Seal sits slightly below the surface. *See figure 6.*



Figure 5



Figure 6

2. **Reinstall** the half coupling, bearing and shaft (items 2, 3 & 4 indicated on the Exploded View on pg. 8-9) as an assembly into the head. If the bearing needs to be replaced it is recommended to purchase a new shaft, bearing and half coupling assembly because the EF Series shaft can be damaged when removing or installing the bearing.

3. **Shaft Installation** - Slide the shaft down through the seal until the bearing engages the bearing bore in the head. Use any size dowel under 1” (25.4 mm) in diameter and press the half coupling, bearing and shaft into place using an arbor press or by lightly tapping with a soft mallet. Note: Do not use excessive force. Unthread the half coupling counter clockwise (right hand thread) to verify that the bearing is seated properly. *See figure 7.* Reinstall the half coupling.



Figure 7

4. **Inner Tube, Center Support & Shaft Sleeve Installation** - for all models - Reinstall the inner tube, center support (if used) and shaft sleeve (items 13, 14 & 15). Slide the shaft sleeve onto the shaft. The shaft sleeve is self-positioning so slide it up as far as it will go on the shaft. Reinstall the inner tube with center support (if used) over the shaft and shaft sleeve. The double o-ring side seats up into the head with a slight twisting motion. Make sure the inner tube is seated properly. The bottom of the inner tube will be flush with the bottom of the outer tube when properly seated.

5. **Outer Tube Installation** - for EFP & EFV models - Install the outer tube (item 16). Make sure the center support (if used) is installed correctly on the inner tube. The center support has a slight taper that allows the outer tube to slide easily over it.

See figure 8. Slide the outer tube with external threads over the shaft, shaft sleeve, inner tube and center support (if used) up into the head (item 6). Turn the outer tube counter clockwise (left hand thread) to tighten it into the head. Hand tighten.

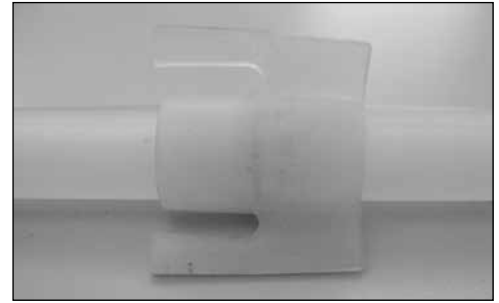


Figure 8

6. **Diffuser Installation** - for all models - Install the diffuser (item 17) onto the bottom of the outer tube. Insert the shaft through the small support opening on the diffuser. See figure 9. The small support opening will insert up inside the inner tube (item 13). With a slight push and turn, thread the diffuser into the outer tube (item 16) turning counter clockwise (left hand thread). EFP and EFV models - only tighten the diffuser halfway or 3-4 turns. See figure 10. Insert the impeller (item 18) into the bottom of the diffuser. With a slight push and turn the impeller should twist through the impeller guards and engage the shaft threads. Use a flathead screwdriver to tighten the impeller to the shaft turning clockwise (right hand thread). See figure 11. Hold the half coupling (item 2) in one hand while turning the impeller with the other. Hand tighten. Once the impeller is tightened, finish tightening the diffuser turning counter clockwise (left hand thread). Hand tighten.



Figure 9



Figure 10



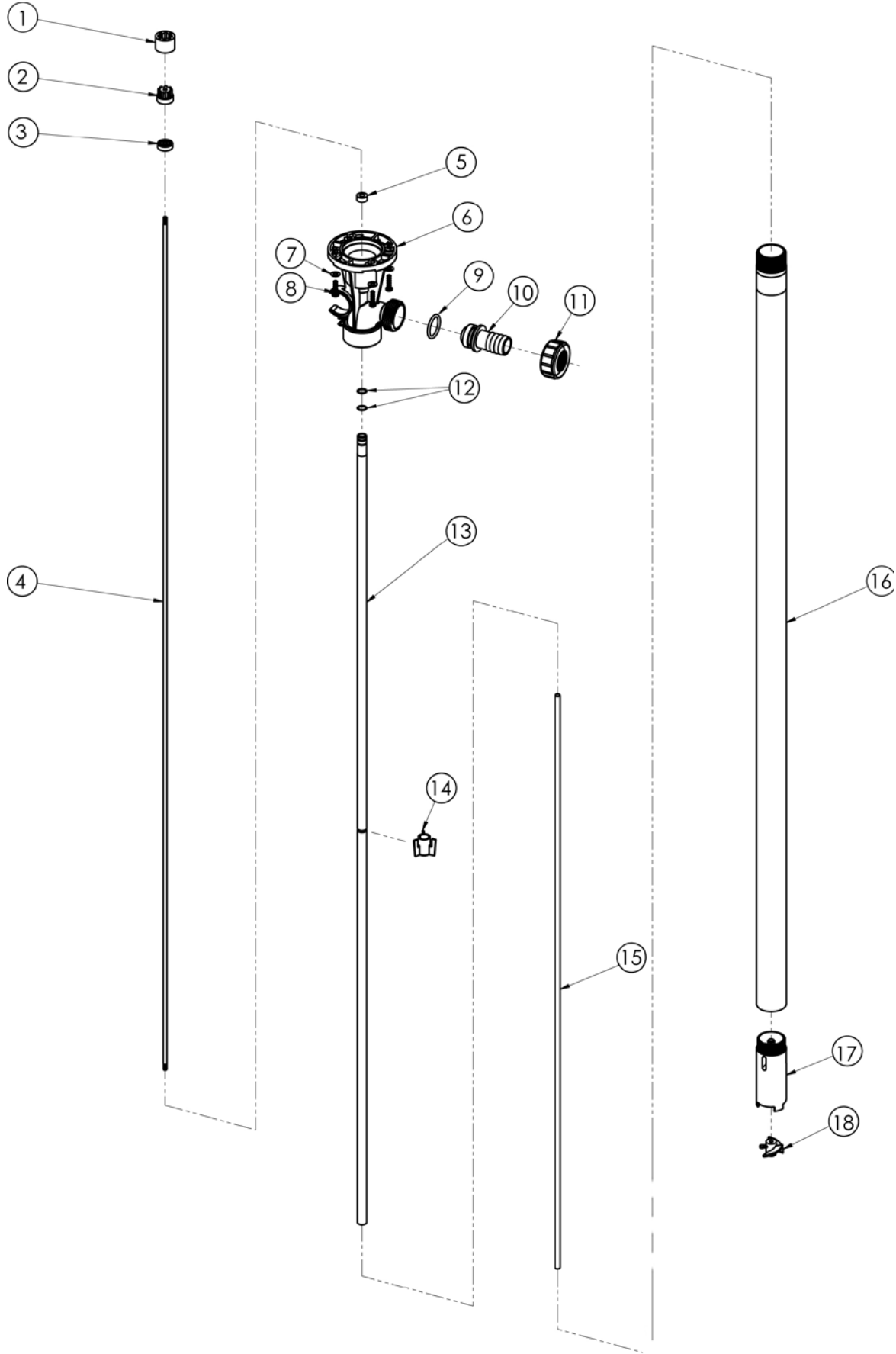
Figure 11

7. **For EFS Models** - Thread the diffuser (item 17) completely onto the bottom of the outer tube (item 16). Thread the impeller onto the shaft by hand. While holding the half coupling with the other hand, turn the impeller clockwise (right hand thread). See figure 12. Install the diffuser cover (item 19), EFS models only, onto the diffuser turning counter clockwise (left hand thread). Hand Tighten.

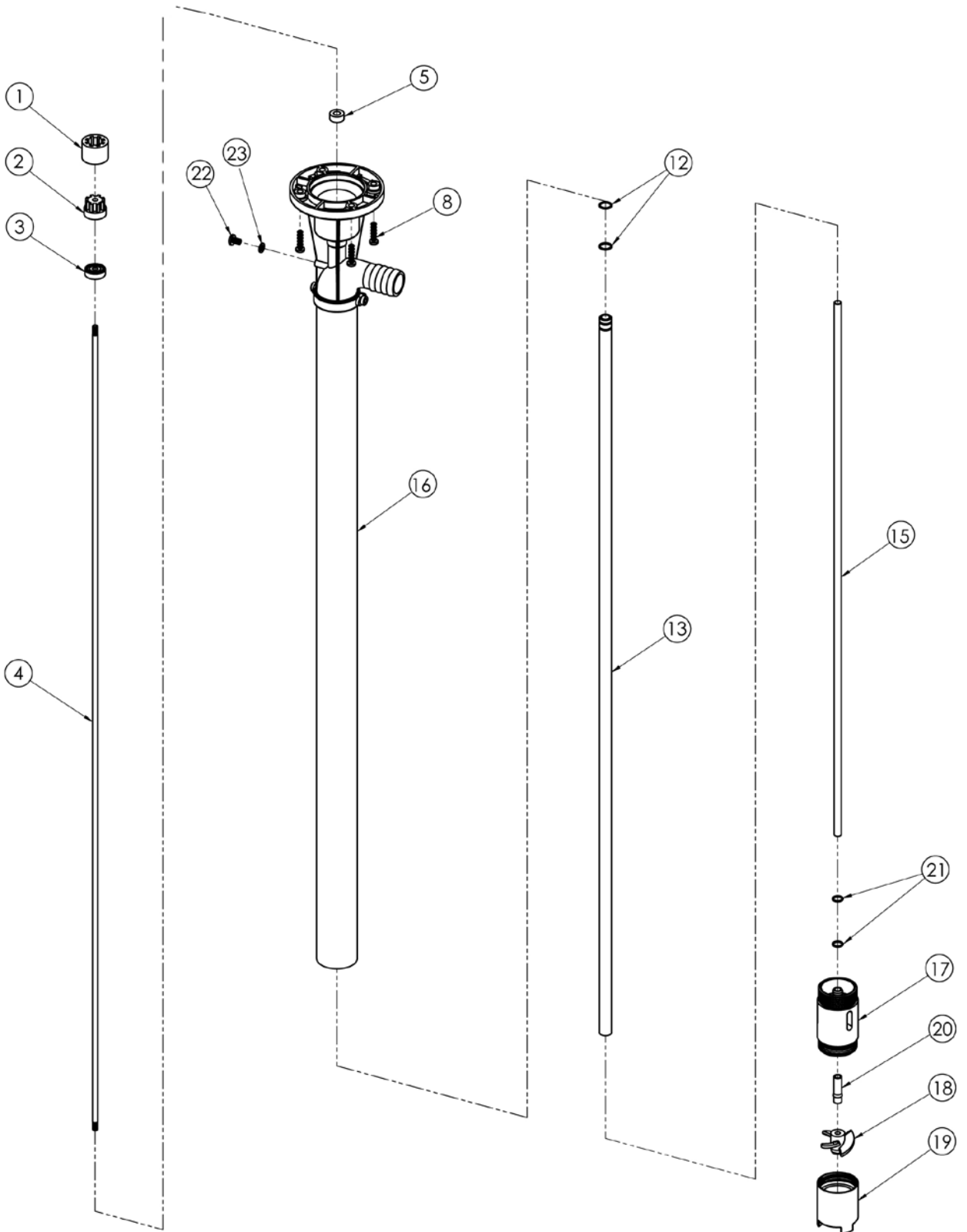


Figure 12

**EFP & EFV SERIES PUMP
EXPLODED VIEW**



**EFS SERIES PUMP
EXPLODED VIEW**



PUMP SPARE PARTS LIST

ITEM	QTY	DESCRIPTION	PART NUMBER		
			MODEL EFP	MODEL EFV	MODEL EFS
*1	1	COUPLING INSERT			
			J103422	J103422	J103422
2	1	COUPLING HALF			
			107300	107300	107300
3	1	BEARING			
		AVAILABLE ONLY AS PART OF COUPLING HALF, BEARING & SHAFT ASSEMBLY			
4	1	SHAFT			
		AVAILABLE ONLY AS PART OF COUPLING HALF, BEARING & SHAFT ASSEMBLY			
*2,3,4	1	COUPLING HALF, BEARING & SHAFT ASSEMBLY			
		COUPLING HALF, BEARING & SHAFT - 16"	107589-1	107590-1	107589-1
		COUPLING HALF, BEARING & SHAFT - 27"	107589-2	107590-2	107589-2
		COUPLING HALF, BEARING & SHAFT - 40"	107589-3	107590-3	107589-3
		COUPLING HALF, BEARING & SHAFT - 48"	107589-4	107590-4	107589-4
		COUPLING HALF, BEARING & SHAFT - 54"	107589-5	107590-5	N/A
*5	1	SEAL			
		FKM	107297	107297	107297
6	1	PUMP HEAD			
		POLYPROPYLENE	107071-1	N/A	N/A
		PVDF	N/A	107071-2	N/A
7	4	FLAT WASHER			
		STAINLESS STEEL	J103601	J103601	N/A
8	4	HI-LOW SCREW			
		STAINLESS STEEL	J101020	J101020	J101020
*9	1	SPOUT O-RING			
		FKM (STANDARD)	106155	106155	N/A
		EPDM	106154	106154	N/A
10	1	SPOUT			
		POLYPROPYLENE	107072-1	N/A	N/A
		PVDF	N/A	107072-2	N/A
11	1	NUT			
		POLYPROPYLENE	107069-1	N/A	N/A
		PVDF	N/A	107069-2	N/A
*12	2	INNER TUBE O-RING			
		FKM (STANDARD)	107299	107299	107299
		EPDM	107729	107729	107729
13	1	INNER TUBE			
		16"	107294-1	107294-1	107578-1
		27"	107294-2	107294-2	107578-2
		40"	107294-3	107294-3	107578-3
		48"	107294-4	107294-4	107578-4
		54"	107294-5	107294-5	N/A
*14	1	CENTER SUPPORT			
		TEFZEL® (ETFE) - 40" & 48" LENGTHS ONLY	107068	107068	N/A
*15	1	SHAFT SLEEVE - PTFE			
		16"	107293-1	107293-1	107293-1
		27"	107293-2	107293-2	107293-2
		40"	107293-3	107293-3	107293-3
		48"	107293-4	107293-4	107293-4
		54"	107293-5	107293-5	N/A
16	1	OUTER TUBE (MODEL EFS INCLUDES PUMP HEAD)			
		16"	107295-1	107295-2	107580-1
		27"	107295-3	107295-4	107580-2
		40"	107295-5	107295-6	107580-3
		48"	107295-7	107295-8	107580-4
		54"	107295-9	107295-10	N/A
*17	1	DIFFUSER			
		POLYPROPYLENE	107070-1	N/A	N/A
		PVDF	N/A	107070-2	N/A
		316 STAINLESS STEEL (W/ PTFE BUSHING)	N/A	N/A	108115

N/A = Not Applicable

ITEM	QTY	DESCRIPTION	PART NUMBER		
			MODEL EFP	MODEL EFV	MODEL EFS
*18	1	IMPELLER			
		POLYPROPYLENE	107067-1	N/A	N/A
		TEFZEL® (ETFE)	N/A	107067-2	107067-2
19	1	DIFFUSER COVER			
		316 STAINLESS STEEL	N/A	N/A	107584
20	1	DIFFUSER BUSHING			
		PTFE	N/A	N/A	107585
*21	1	DIFFUSER O-RING			
		FKM (STANDARD)	N/A	N/A	107586
		EPDM	N/A	N/A	107766
22	1	GROUNDING SCREW			
		BRASS	N/A	N/A	J100822
23	1	GROUNDING SCREW LOCKWASHER			
		BRASS	N/A	N/A	J100823
N/A = Not Applicable					

* Recommended Spare Parts

Tefzel® is a registered trademark of the DuPont Company.



FINISH THOMPSON INC.

921 Greengarden Road • Erie, PA 16501-1591 U.S.A.

Ph 814-455-4478 • Fax 814-455-8518

Email fti@finishthompson.com • www.finishthompson.com

Service 1-800-888-3743
P/N 107317, Rev8, 3-5-13